

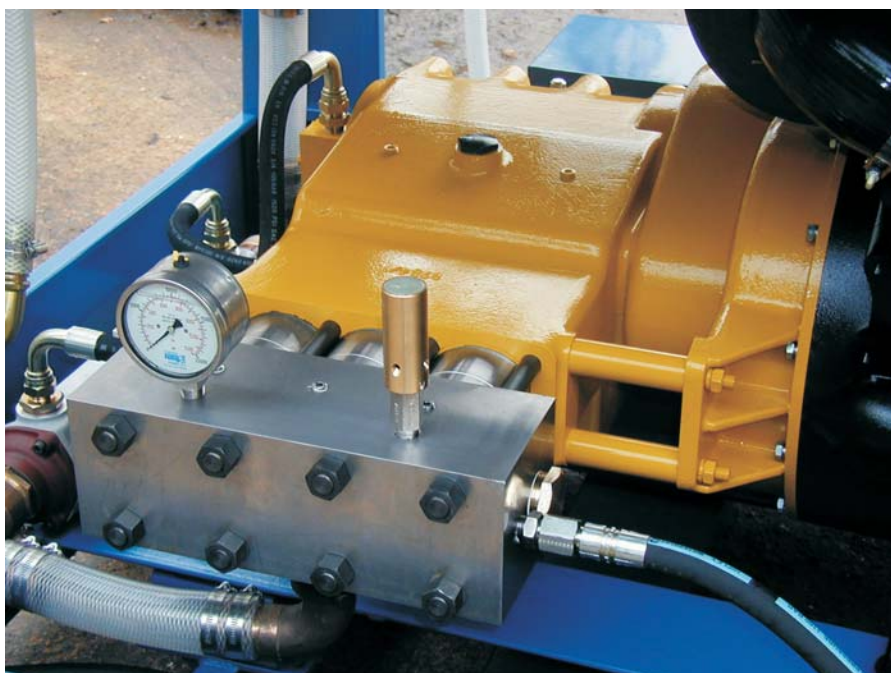

HPS1600

HIGH PRESSURE TRIPLEX PUMP



Features:

- * Robust, rugged and reliable
- * Versatile (interchangeable fluid heads and plunger kits)
- * Stainless steel fluid heads (431 standard or 316)
- * 160 kW (215 hp) input
- * Hardened, alloy steel crankshaft with heavy duty roller and steel backed white metal main bearings, supported between each connecting rod
- * SG iron crankcase with splash lubrication and oil cooling
- * Forged connecting rods with low friction, shell type big end bearings and lead bronze lined small end bushes

Build Options:

- * Choice of gear ratio to suit electric motor or diesel engine drive
- * Standard adaptor housings (SAE 1, 2 or 3) for flange mounting the pump to a diesel engine flywheel housing or electric motor
- * Piston kits for high volume applications
- * Safety relief valves
- * Unloading valves
- * Selector/Diverter valves (manual or actuated)
- * Complete unit build or bare shaft pump only

Pump Head Type	High Pressure			Intermediate				High Volume				
Diameter - mm	28	30	35	40	45	50	55	60	65	70	75	80
Input Power - kW	110	126	160	160				160				
Pump Speed - rpm	400			400				400				
Flow Rate - l/min	59	68	92	120	152	188	228	271	318	369	424	482
Pressure - bar	1000		940	720	565	460	380	320	270	235	200	180

Flow Rates indicated are swept volume at maximum speed

A robust design, the HPS1600 has a specification producing a heavy duty capability for dealing with the more difficult problems of industry.

The close coupled, gear driven power end has splash lubrication and oil cooling. Standard adaptor housings are available enabling the pump to be flange mounted to a diesel engine flywheel housing or electric motor ensuring extremely compact and

perfectly aligned installations.

For maximum hydraulic efficiency, the in-line valve pump head arrangement is designed to minimise the unswept volume.

This improved design is capable of high pressure to high volume with outstanding seal, plunger and valve life.

General Dimensions - typical pump build

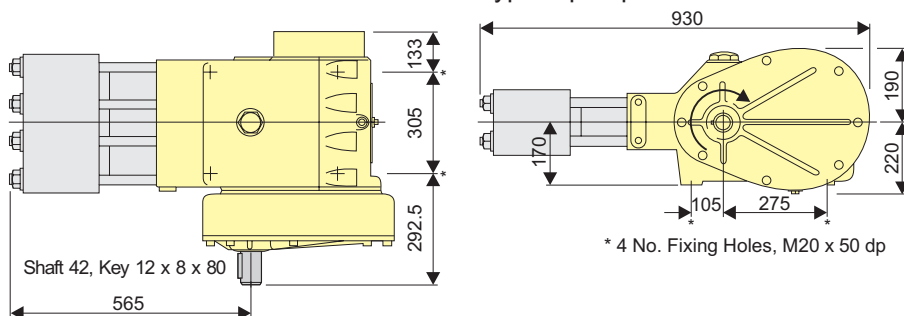

Approx weight - 475 kg (with gearbox)



Ultra High Waterblasters (Aus) Pty Ltd

9 Deebing Street, West Ipswich, Qld 4305

Phone: +61 (07) 3812 1112 Fax: +61 (07) 3812 1115

Email: info@auswaterblasters.com.au

Website: www.auswaterblasters.com.au

In line with the Company's policy of research and development, alterations in design, dimensions and appearance are incorporated from time to time in order to ensure that important developments are included at the earliest opportunity. The Company, therefore, reserves the right to alter design, dimensions etc without notice.